

# TTS450

## Fully Automatic Tripod Turnstile



Date: 28 April 2013, Revision: V1

### General Description

TTS450 retain same durable design of manual turnstile while integrating precise motor to fully automate turnstile rotation functionality. They allow pedestrian to just push the arm lightly and it will rotate automatically allowing passage.

TTS450 adopt precise photo electricity limit and gear to orient the closure. Ensure the closure much more precise, stable and smooth; greatly reduce the collision of mechanism.

### Application

TTS450 are suitable for indoor and shaded outdoor application only. TTS450 always install in entrance of club house, college, theme park, ticketing checkpoint for mass transportation.

### Features

TTS450 can be bi-direction transit. The arm of the turnstile of the turnstile can be set to bi-direction passing or single-direction passing to control pedestrian movement direction.

TTS450 arm can be automatic down when power is off to allow free passing, ensure people able to evacuate in short time during emergency cases. After power recover, then arm will automatically rotate and rise up.

LED direction indicator at top cover. Green arrow or red cross mark will be shown at top cover to indicate the correct direction to allow access.

MAG Unified Compact motor technology allows controller board, motor and gearbox to be built into a single unit for easy future maintenance and replacement.

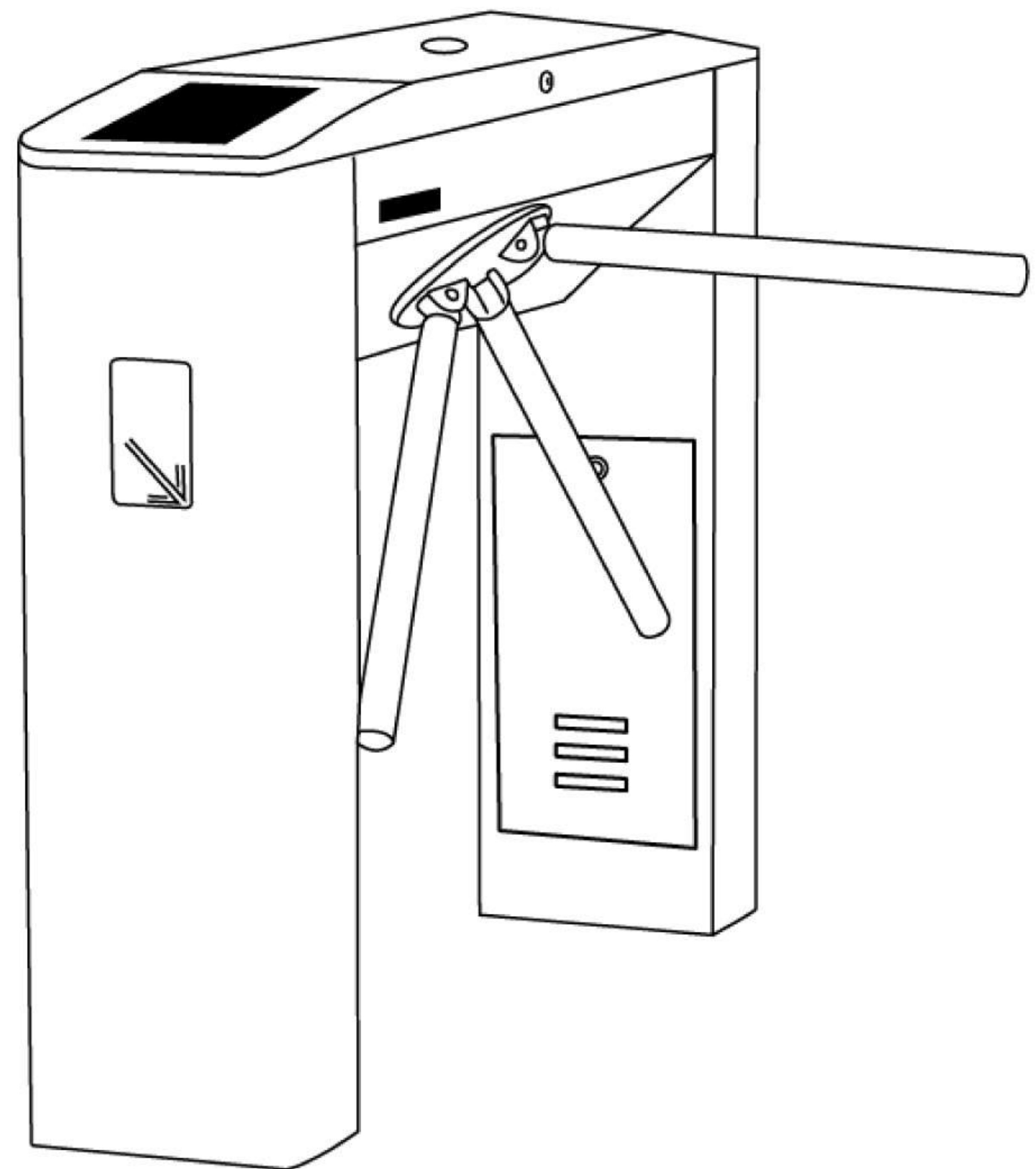

Able to integrate with variety of ticketing reader, card access control, pin access control and bio-metric access control that further enhance the security and monitoring of management. Top cover can be fully opened to allow easy installation of reader and additional control system.

Auto reset function. After the card have been read, if within a specific time (can be set) there is no user pass by, system will automatic cancel the transit right for this time. Arm shall automatically return to home position.

Motorized automatic arm, built in intelligent motor allow arm turning operation more effortless and easy.



## Technical specification

Description	Parameter
Cabinet dimension	1235mm (L)*280mm (W)*1020mm (H)
Length of the arm	490mm
Largest endurance of arm	80Kg
Driving force of arm	80Kg
Power supply	AC230±10%V 50Hz
Rated Power	50W
Motor voltage	DC 12V
Max flow rate	20 to 32 people per minute
Rotating speed of motor	800 RPM
Working temperature	-25°C - 55°C
Input Socket	12V electrical level signal > 100ms 12V impulse signal driving current > 10mA

## Dimension Specification

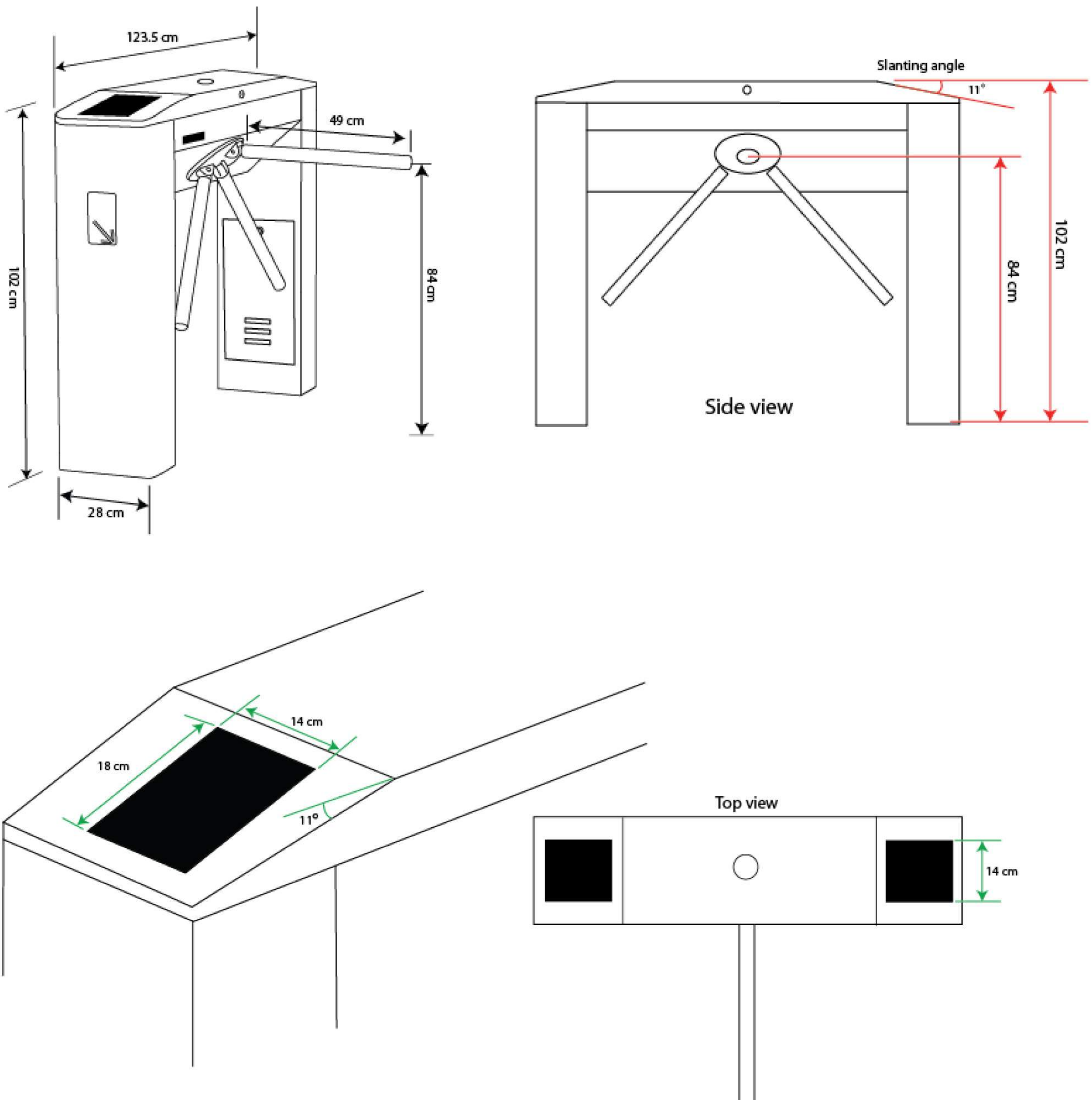



# Machine Core Structure

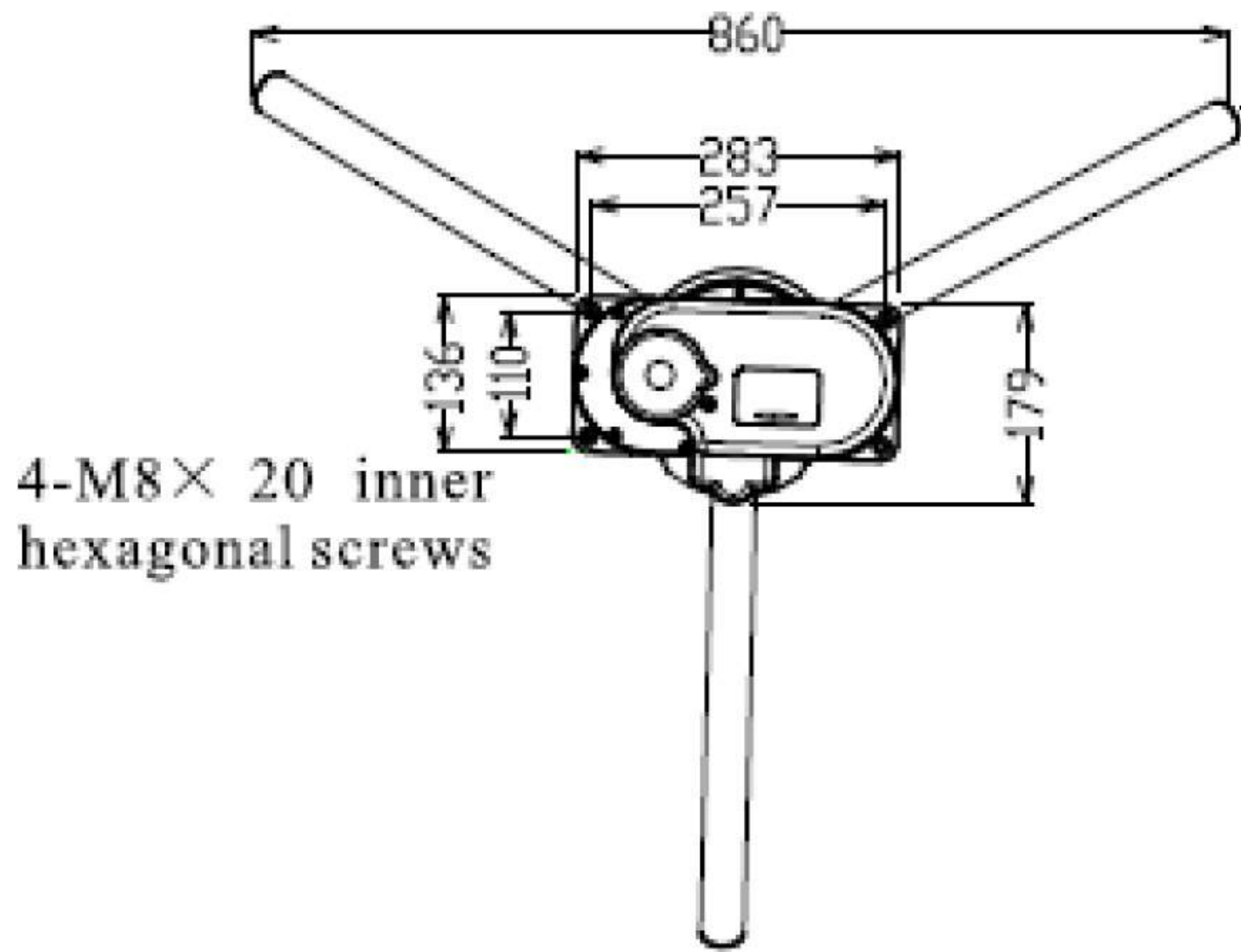

Down View of Machine Core

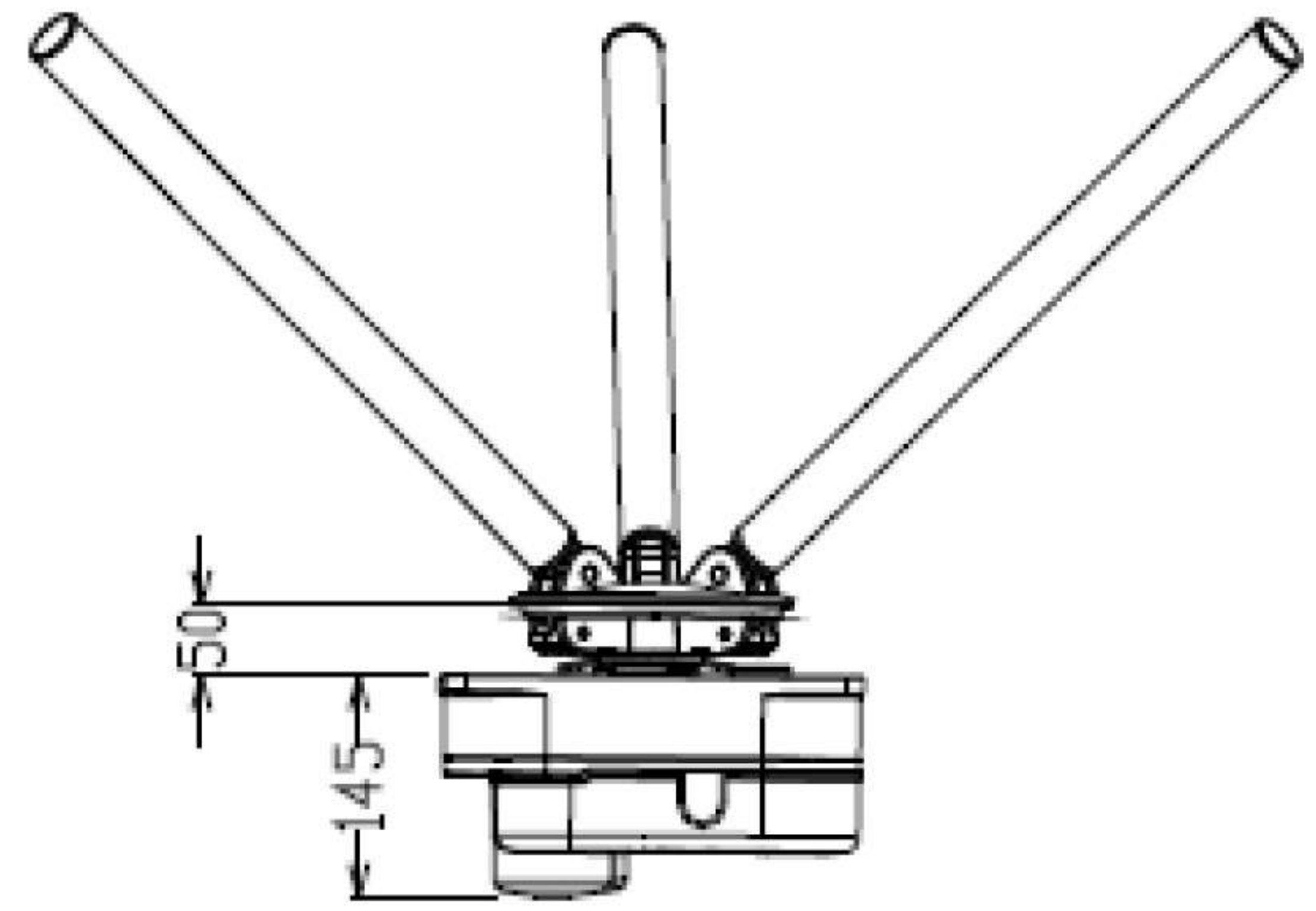

Front View of Machine Core

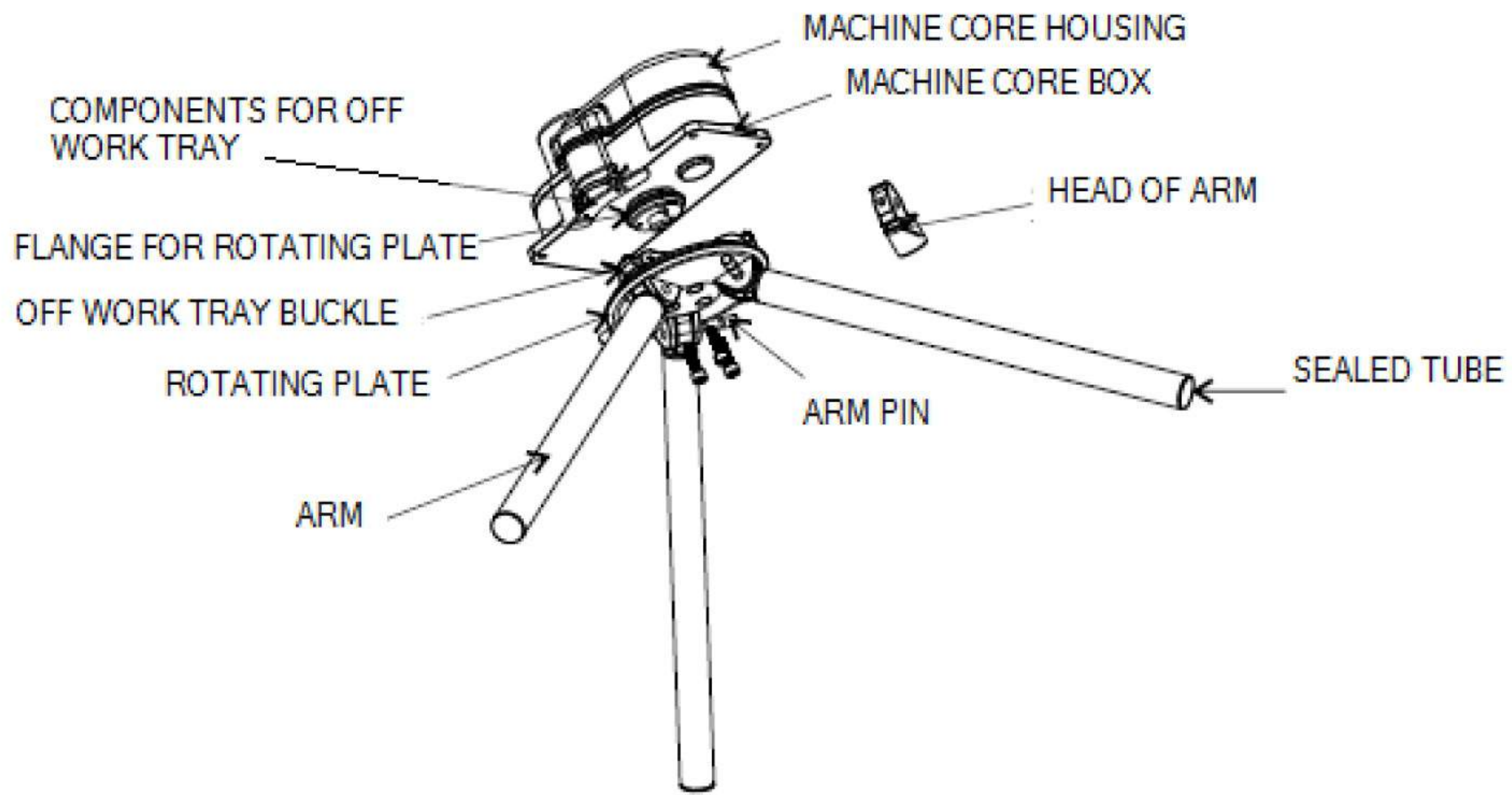

## LED Display Pattern

Following LED display is available at the leg to indicate if this direction is allowed to pass through or not. LED display is programmable from control board.

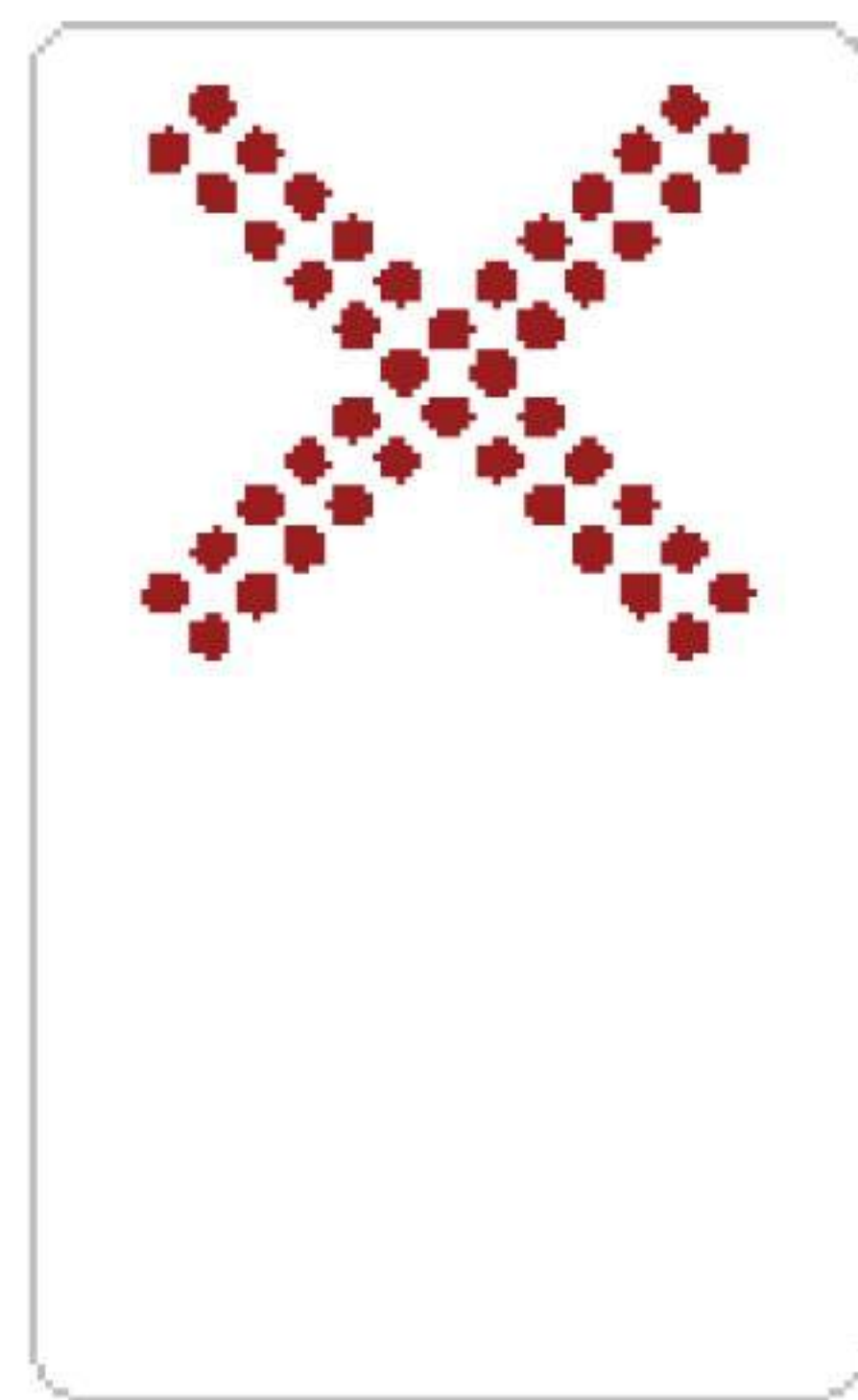

Forbid Passing

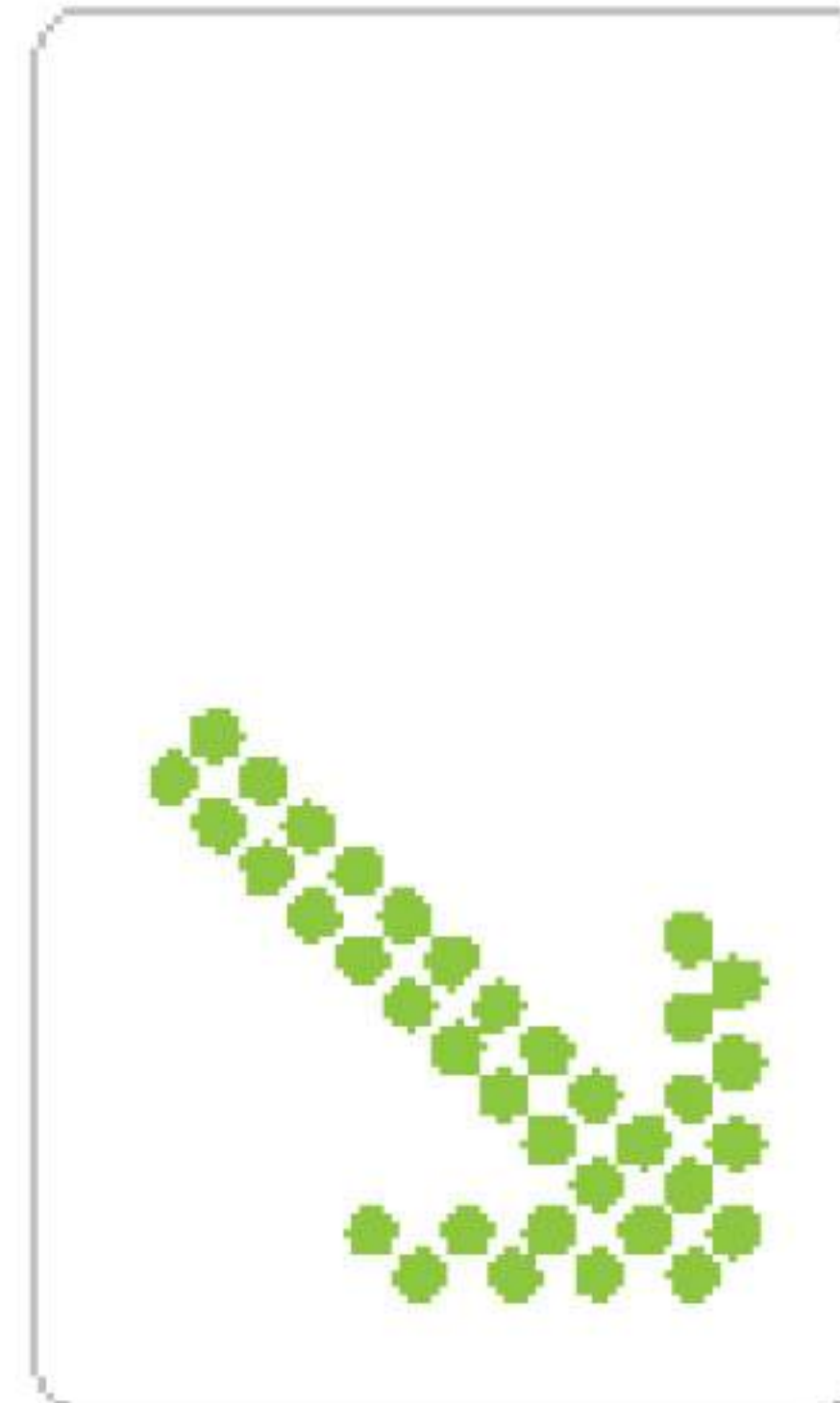

Allowed Passing



## Optional Accessories

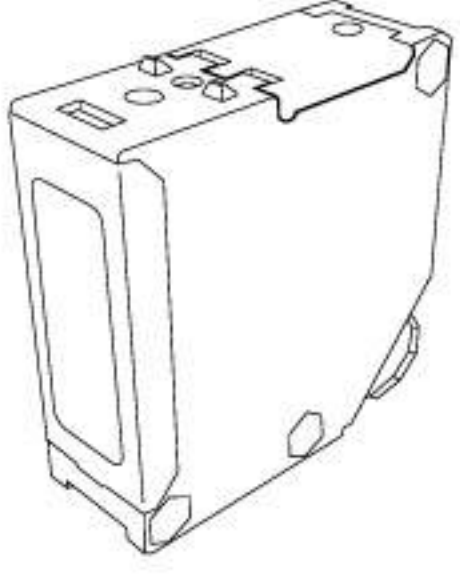

### ESQ501

Infrared sensor - detect presence of human, vehicle and other object for automated opening.

## Packaging Information

Turnstile Net Weight	70 kg
Turnstile Net Dimension	123.5(L) x 28(W) x 102(H) cm
Turnstile weight with packaging box	91 kg
Turnstile dimension with packaging box	143 x 128 x 43 cm

Authorized dealer:



### Disclaimers

Applications that are described herein for any of these products are for illustrative purposes only. Drawing does not necessary reflect exact assembly/installation. MAG makes no representation or warranty that such applications will be suitable for the specified use without further testing or modification.

MAG reserves the right to make changes, without notice, in the products, including circuits, standard cells, and/or software, described or contained herein in order to improve design and/or performance. The Weight and dimension might slightly difference with product. MAG assumes no responsibility or liability for the use of any of these products, conveys no license or title under any patent, copyright, or masks work right to these products, and makes no representations or warranties that these products are free from patent, copyright, or mask work right infringement, unless otherwise specified.

© MAG. All rights reserved. Date released: 28 Apr 2013